

SOLLEVATORI OLEOPNEUMATICI DA FOSSA AIR HYDRAULIC PIT JACKS

- I** Sollevatore oleopneumatico da fossa sospeso, completamente automatico adatto al sollevamento di mezzi pesanti o all'assistenza e alla manutenzione di cambi e differenziali. La nostra gamma vanta circa 60 diversi modelli e personalizzazioni, ideate e pensate per soddisfare ogni esigenza. Alle 2 diverse centraline, (EASY E TOP) affianchiamo traverse standard di 3 altezze differenti e 2 pistoni con corsa di 600 e 800mm. Lo spostamento all'interno della fossa è garantito dai 4 rulli con cuscinetti, forniti con la traversa. I modelli 1620 e 1820 vengono forniti esclusivamente con traversa CUSTOMIZED, costruita con le misure della fossa del cliente. Su tutti gli altri modelli, è possibile richiedere la personalizzazione della traversa. È inoltre disponibile una vasta gamma di accessori. Ideale per officine con fosse.
- F** Cric oléopneumatique de fosse suspendu, complètement automatique, adapté au levage de véhicules lourds ou pour l'assistance et l'entretien des boîtes de vitesse e des différentiels. Notre gamme comprend environ 60 modèles et personnalisations différents, conçus et étudiés pour satisfaire toutes les exigences. Pour les 2 différentes centrales (EASY E TOP), sont fournis des traverses standard de 3 hauteurs différentes et 2 pistons avec course de 600 et 800 mm. 4 rouleaux avec roulements, fournis avec la traverse, garantissent le déplacement à l'intérieur de la fosse. Les modèles 1620 et 1820 sont fournis exclusivement avec la traverse CUSTOMIZED, construite en fonction de la taille de la fosse du client. Sur tous les autres modèles, on peut demander la personnalisation de la traverse. Par ailleurs, nous fournissons une vaste gamme d'accessoires. Idéal pour les garages avec fosse.

- GB** Suspended air hydraulic pit jack, fully automatic, suitable for lifting heavy vehicles or for the assistance and maintenance of speed and differential gears. There are 60 different models and customisations in our range, conceived and designed to meet all requirements. Standard jacking beams available in 3 different heights and 2 pistons with a stroke of 600 and 800 mm are for use with the 2 different control units (EASY and TOP). Movement inside the pit is guaranteed by 4 rollers with bearings, supplied with the jacking beam. Models 1620 and 1820 are only supplied with a CUSTOMISED jacking beam, made with the measurements of the customer's pit. Customisation of the jacking beam can be asked for on all the other models. A wide range of accessories is also available. Ideal for workshops with pits.
- D** Ölpneumatischer, hängender Grubenheber, völlig automatisch, für das Heben von Schwertransportern geeignet oder für die Reparatordienst und Wartung von Getrieben und Differentialen. Unsere Produktpalette verfügt über ca. 60 verschiedene Modelle und persönliche Gestaltungen, die konzipiert und erdacht wurden, um jedes Bedürfnis zu erfüllen. Neben die 2 verschiedenen Steuergehäuse (EASY UND TOP) stellen wir Standardtraversen mit 3 verschiedenen Höhen und 2 Kolben mit Hub von 600 und 800 mm. Die Verschiebung innerhalb der Grube wird durch 4 Rollen mit Lagern garantiert, die mit der Traverse geliefert werden. Die Modelle 1620 und 1820 werden ausschließlich mit der Traverse CUSTOMIZED geliefert, die mit den Abmessungen der Grube des Kunden konstruiert wurde. Bei allen anderen Modellen ist es möglich, die persönliche Gestaltung der Traverse zu erbeten. Außerdem ist eine weitreichende Palette an Zubehörteilen erhältlich. Ideal für Werkstätten mit Gruben.

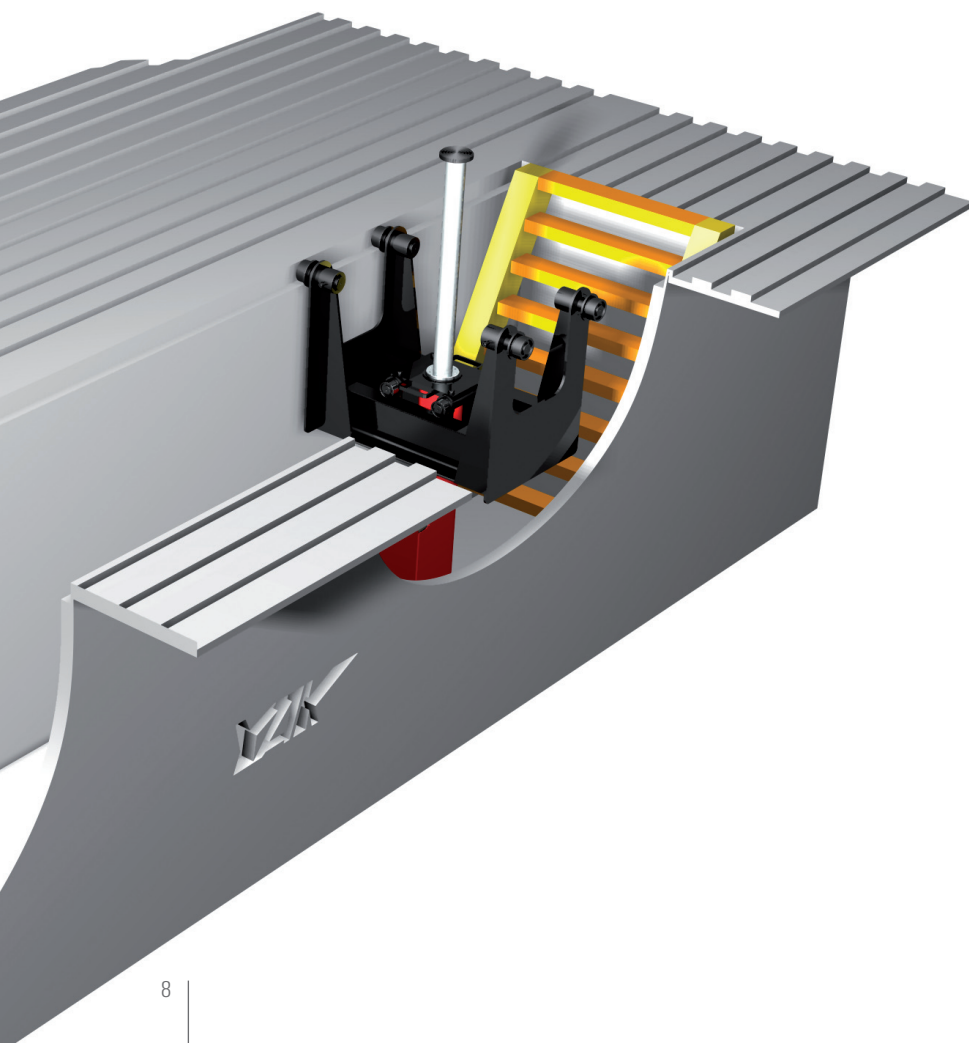

- E** Gato oleoneumático suspendido para fosas, completamente automático, idóneo para elevar vehículos pesados o para la asistencia y el mantenimiento de cajas de cambios y diferenciales. Nuestra gama tiene unos 60 modelos diferentes y personalizaciones ideadas ya pensadas para satisfacer cualquier exigencia. Con las 2 diferentes centralitas (EASY E TOP) asociamos traviesas estándar con 3 alturas diferentes y 2 pistones con una carrera de 600 y 800mm. El desplazamiento dentro de la fossa está garantizado por los 4 rodillos con rodamientos, suministrados con la traviesa. Los modelos 1620 y 1820 se suministran exclusivamente con traviesa CUSTOMIZED, construida con las medidas de la fossa del cliente. En todos los otros modelos se puede pedir la personalización de la traviesa. También está disponible una extensa gama de accesorios. Ideal para talleres con fosas.
- P** Macaco oleopneumático para fossa suspenso, completamente automático, apropriado para o levantamento de meios pesados ou para a assistência e a manutenção de mudanças e diferenciais. A nossa gama dispõe de aproximadamente 60 modelos diferentes e personalizações, criadas e pensadas para atender quaisquer exigências. As 2 diferentes centrais, (EASY E TOP) ladeamos travessas padrão de 3 alturas diferentes e 2 pistões com 600 e 800mm de corrida. A deslocação no interior da fossa é garantida pelos 4 rolos com rolamentos, fornecidos com a travessa. Os modelos 1620 e 1820 são fornecidos exclusivamente com travessa CUSTOMIZED, construida com as medidas da fossa do cliente. Em todos os outros modelos, é possível pedir a personalização da travessa. É ainda disponível uma vasta gama de acessórios. Ideal para oficinas com fossas.

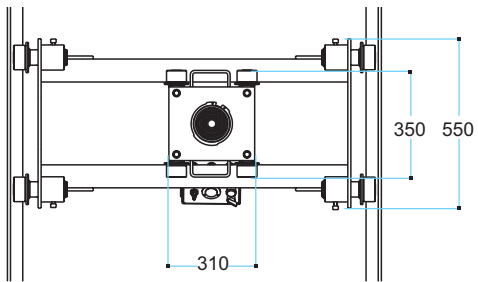
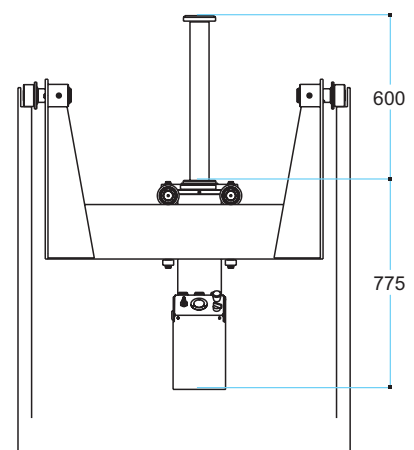

Mod. **YAK 1610**
YAK 1615
YAK 1620



YAK 1810
YAK 1815
YAK 1820

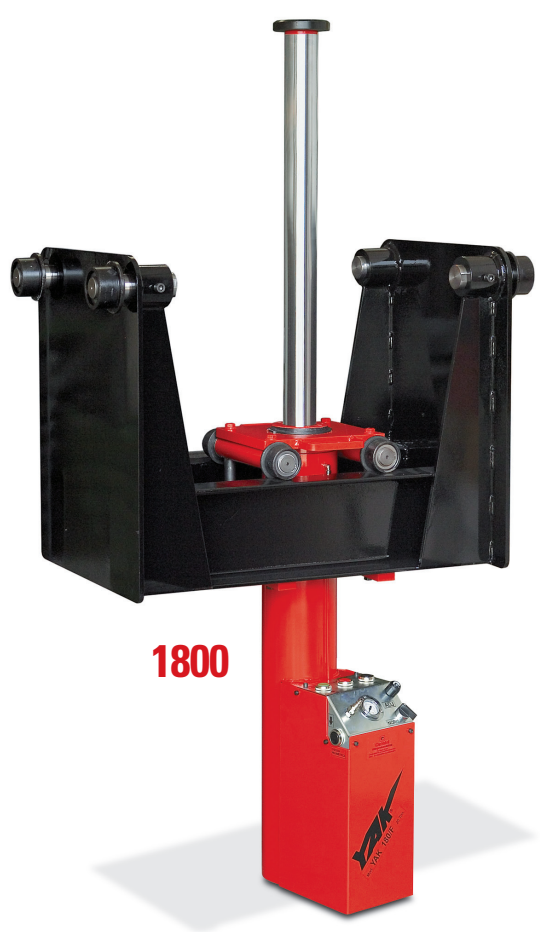
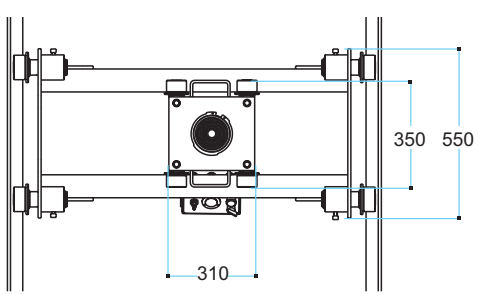
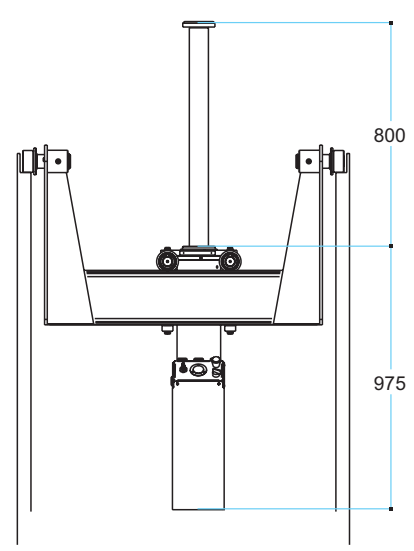
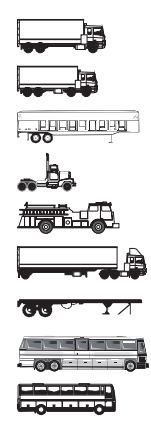

SOLLEVATORI OLEOPNEUMATICI DA FOSSA AIR HYDRAULIC PIT JACKS

Articolo Item	Corsa Stroke		Portata Capacity		Larghezza fossa Pit width		Altezza traversa Beam height			Comandi Controls		
	(mm)	(t)	(US ton)	Standard (mm)	Cod. personalizzata Cod. Customized	Cod.	Cod.	Cod.		Cod.		Cod.
YAK 1610	600	10	11	850-1015	C	S	M	L	Easy	E	Top	T
YAK 1615	600	15	16,5	850-1015	C	S	M	L	Easy	E	Top	T
YAK 1620	600	20	22	Solo personalizzata Only customized	C	S	M	L	Easy	E	Top	T
YAK 1810	800	10	11	850-1015	C	S	M	L	Easy	E	Top	T
YAK 1815	800	15	16,5	850-1015	C	S	M	L	Easy	E	Top	T
YAK 1820	800	20	22	Solo personalizzata Only customized	C	S	M	L	Easy	E	Top	T

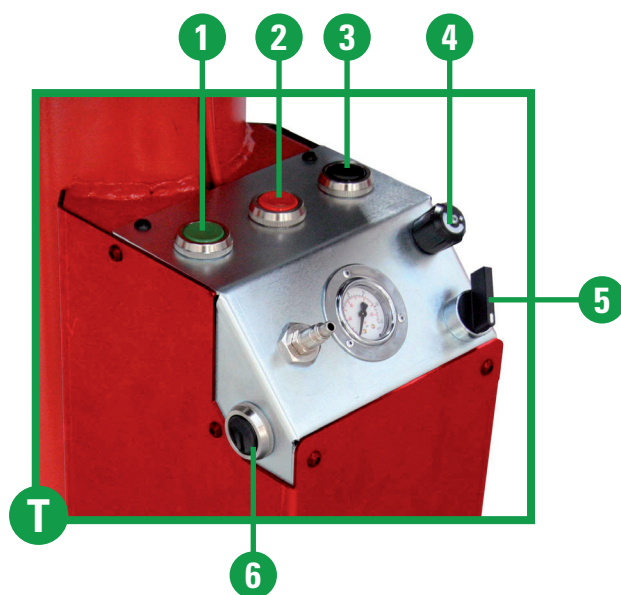

- 1_ Avvicinamento rapido
- 2_ Sollevamento
- 3_ Discesa rapida
- 4_ Regolazione velocità motore/sollevamento
- 5_ Selettore velocità motore/sollevamento
- 6_ Discesa millimetrica

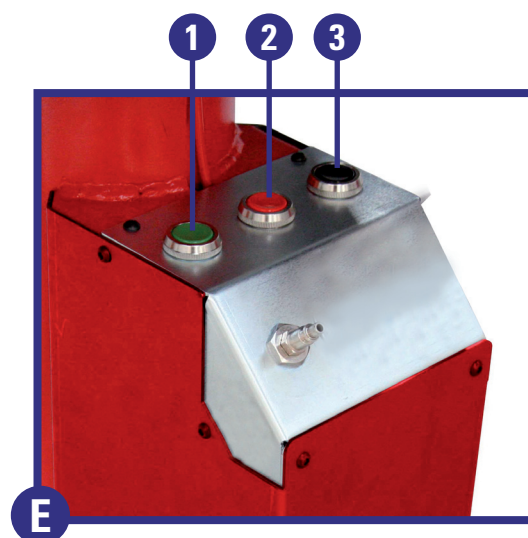

- 1_ Quick approach
- 2_ Lifting
- 3_ Quick descent
- 4_ Adjusting motor speed/lifting
- 5_ Motor speed/lifting selector
- 6_ Fine jack drop adjustment

Mod.

YAK 1610
YAK 1615
YAK 1620



YAK 1810
YAK 1815
YAK 1820

