



NEW

CEMB ER

Er Go Fast Line 85



*Video touch screen
balancing machine*

Italian style

3D

Automatic measurements
by sonar

TOUCH

Heavy-duty touch screen

LASER

Laser for weight positioning
inside the rim

LED

Led to light working space

WBA

Wheel Best Access

VDD

Virtual Direct Drive
(CEMB patent)

EMS

Sonar eccentricity

PL

Pneumatic Locking
of the wheel

Option

Zero weight



Wheel lift





NEW

CEMBER

Er Go Fast Line 85

From CEMB experience...

- **ER85 balancer** is the result of CEMB consolidated experience in the manufacturing of high technology garage and industrial balancers since 1946. Development and cooperation with the most important car and tyre manufacturers guarantee to the professionals in the garage equipment field:

- *Reliability*
- *Easy and quick use*
- *Accuracy*
- *Completely configurable*
- *Extremely fast cycle time!*

Core of technology

- **VDD (Virtual Direct Drive)** very quick and maintenance free measurement system (CEMB patent)
- Lock of wheel in the correction position by means of an **electromagnetic brake**
- **LA SONAR (CEMB patent)** for automatic measurement of the wheel width
- Software programs for the professionals: **SPLIT, OPT, ALU**
- **NEWS! Extended gauge** for diameter and distance measurement of rims up to 28", with automatic locking on correction planes. New pincer to hold the adhesive weight
- Multi-user icon selectable on the touch screen

- Tyres set
- **Led light** to illuminate the working space inside the rim
- **Laser indicator** for correction positioning inside the rim



- **ALU-S** balancing mode (adhesive weights on the internal rim planes) with specific counterweight position indicator (position repeater)



- **Eccentricity measurement** with sonar (1st Harmonic and Peak to Peak) Automatic and quick eccentricity measurement during the normal balancing cycle
- Alarm signal if radial eccentricity is out of tolerance

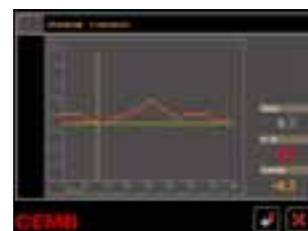

Italian style

- New ergonomic, easy-use and essential design
- **WBA Wheel Best Access** Wide space to work inside the rim
- Innovative video touch
- Ergonomic tool positioning close at hand



- **Pneumatic wheel locking (Cemb Patent)**
 - Floor to floor time reduction
 - Extremely easy and quick to use
 - Very accurate wheel centering



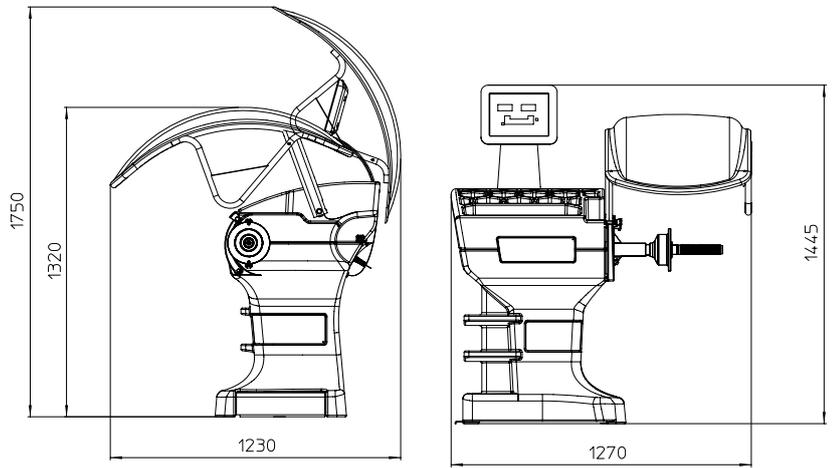

Single phase power supply	115 / 230 V 50/60 Hz
Max. absorbed power	0,15 Kw
Balancing speed	100 rpm
Measuring cycle for 15 kg (33 lb) wheel	4.7 s
Measurement uncertainty	0,5 g
Average noise	< 70 dB (A)
Rim width setting range	1.5" ÷ 20" / 40 ÷ 510 mm
Rim diameter setting range	10" ÷ 30" / 265 ÷ 765 mm
Min./Max. compressed air pressure	8 ÷ 10 Kg/cm ² ~ 0.8 ÷ 1 Mpa ~ 8 ÷ 10 Bar ~ 115 ÷ 145 Psi
Max. wheel weight	< 75 kg
Machine weight	120 kg

STANDARD ACCESSORIES

In 1952 Cemb created the cone adapters for balancing machines and since then the company continued developing and producing high precision centering systems for any type of wheel. **Cemb does not recommend the use of non-original adapters on its balancing machines.**

UC20/SE2 41FF52768



Pneumatic locking

Standard equipment composed of: 3 cones Ø 45÷ 110 mm, quick locking sleeve SE2, width gauge, pincer-hammer and 60 g counterweight.



OPTIONAL ACCESSORIES Especially designed for car manufacturers



RL cup 41FF79255

Large plastic cup with polyurethane protection ring for light alloy rims.

UH20/2 41FF42048

Universal adapter for all wheels with 3,4,5,6 holes (pitch circle Ø 95-210 mm) complete with high precision back centering double cone (Cemb patent) for wheels with/without central hole (Renault, Peugeot and Citroën). Grants double accuracy compared to similar adapters on the market.

Peugeot - Citroën kit 41FF73171

High precision kit composed of: 3 bushes Ø 58mm, 60mm, 65mm + 2 cones (Ø 62 ÷ 68 mm and Ø 54 ÷ 60 mm). Developed according to Peugeot and Citroën specifications.

VL/2 cone + G36 disc 41FF86174

Kit for light truck wheels (Ø 97 ÷ 170mm central hole).

SR4/SE - SR5/SE - SR5/2/SE SR/USA/SE - SR Premium Package

Stud adapters for rim protection and high precision centering for wheels with 4 or 5 holes. Studs are made of two pieces, elastically coupled: pressure is therefore homogeneous on all the holes.

Renault kit 41FF77152

High precision kit composed of: 5 bushes (Ø 60 / 66 / 71 / 88 / 129,9 mm). Developed according to Renault specifications.

MT cone 40FF57321

High precision graduated cone for German cars (with central hole Ø56,5 / 57 / 66,5 / 72,5 mm).

Mercedes kit 41FF88003

High precision kit composed of: 3 cones (Ø 57- Ø 66,5 -Ø 84/85mm) + 1 pressure spring, according to Mercedes Benz specifications.

For more information see the complete brochure on the web site www.cemb.com

Option to increase your profitability ZERO WEIGHT Lift

ZERO WEIGHT

Zero gravity effect
Wheel loading and removal without effort or adjustment

PERFECT CENTERING

Wheel automatic lifting
Ideal centering and more accurate balancing

QUICK

Quicker than any other traditional lift
A single pedal controls the whole working cycle

AUTOMATIC

Electronic system with PLC

UNIVERSAL

Applicable to any CEMB
balancing machine



Some of our customers:

FERRARI • MASERATI • LAMBORGHINI •
MERCEDES-BENZ • BMW • VOLKSWAGEN • FIAT •
LANCIA • ALFA ROMEO • FORD NISSAN • RENAULT
• HARLEY DAVIDSON • HONDA • YAMAHA • SUZUKI
• KAWASAKI • KTM • DUCATI • TRIUMPH • APRILIA -
PIAGGIO • MOTO GUZZI • PIRELLI • BRIDGESTONE
• MICHELIN • CONTINENTAL • DUNLOP •
GOODYEAR • BREMBO • METZELER

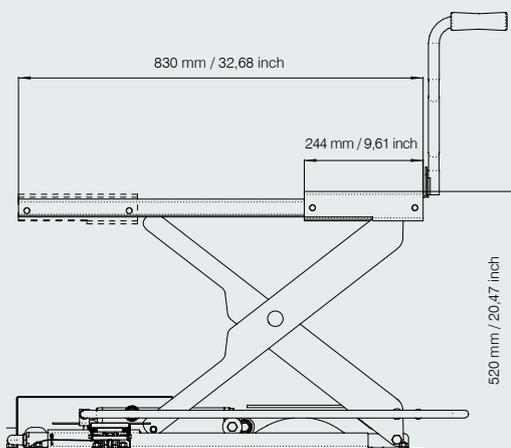

For more information see the complete brochure on the web site www.cemb.com



CEMB

BALANCING MACHINES



CEMB S.p.A.

Via Risorgimento, 9
23826 Mandello del Lario (LC) Italy
www.cemb.com



Garage equipment division

CEMB - ITALY

Plant and Training Center

phone +39 0341 706369
fax +39 0341 700725
garage@cemb.com

CEMB USA

BL Systems Inc.

2873 Ramsey Road
Gainesville, GA 30501 - USA
Phone +001 678 717 1050
Fax +001 678 717 1056
sales@cemb-usa.com

Cemb technology



ITALIAN HEART: All parts which influence the quality of our balancers are manufactured within Cemb through appropriate machinery. The tolerances used are the most accurate on the market. Only in this way it is possible to maintain a constant and accurate balancing through time.

VDD - New: Defined as a "Maintenance Free" concept, it allows maximum accuracy in minimum time, increasing reliability and features of all Cemb balancers. This has been possible thanks to a new patented system of measurement (both mechanical and electronic) as a result of Cemb's unique experience in the field of industrial balancing and vibration analysis instrumentation. With the VDD even the most economic Cemb balancer wins against any of its competitors in both speed and accuracy.



CEMB FOR THE ENVIRONMENT

Our machines save much more energy than you would think! We care for the environment, as much as we care for your costs: these are our priorities. Save money! Save the environment!
Buy our machines. Ask for more details, we are at your full disposal.



All the data and features mentioned in this catalogue are purely for information and do not constitute any commitment on the part of our company, which reserves the right to make any and all alterations it may consider suitable without notice.