



NEW

# DWA1500

**CEMB PATENT**

Revolutionary combined  
Car-Truck alignment system



**Li<sup>+</sup>**

Lithium Powered

**BT<sup>2</sup>**

BT<sup>2</sup> Communication



Featherweight Sensors

**CEMB DWA**



NEW

# DWA1500

**CEMB PATENT**

Truck mode



Car mode



**SWITCH AND TILT HEADS**



## ADVANTAGES



**Lithium batteries:**  
**FORGET YOU EVEN HAVE THEM**

Charge last 24 hours under normal use  
1 year guaranteed battery life



**Innovative BT<sup>2</sup> wireless communication:**  
**IMMEDIATE AND OBSTACLE-FREE CONNECTION**



**Featherweight sensors:**  
**2.6 / 2.8 Kg**



**Silicon accelerometer:**  
**SHOCK-PROOF**



**Store and recharge sensors together with clamps:**  
**DON'T WASTE TIME DISMANTLING**



**SUNLIGHT FILTER**  
Over 12m wheel base even in outdoor sun exposed environment

**NEW**

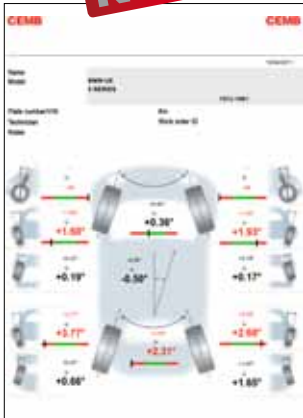

3D Print out

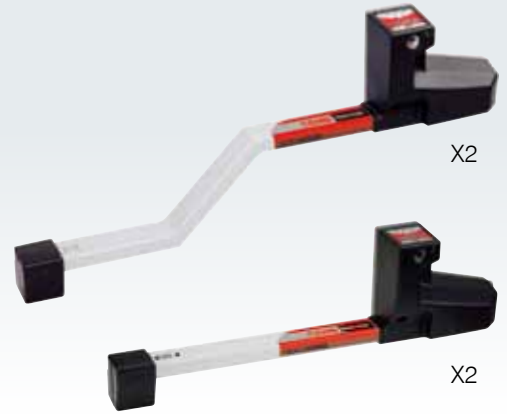

FAST caster swing



Adjust two axles in one screen



Step by step procedure up to 7 axles



2 measuring heads mode  
Quick measurement of front axle

**STANDARD CONFIGURATION**

**OPTIONAL ACCESSORIES**



12" - 24" mm



Optional up to 30"

Metal 120 mm universal grips with reference surface for truck and bus wheels

45 mm universal grips

48 mm reference surface grips

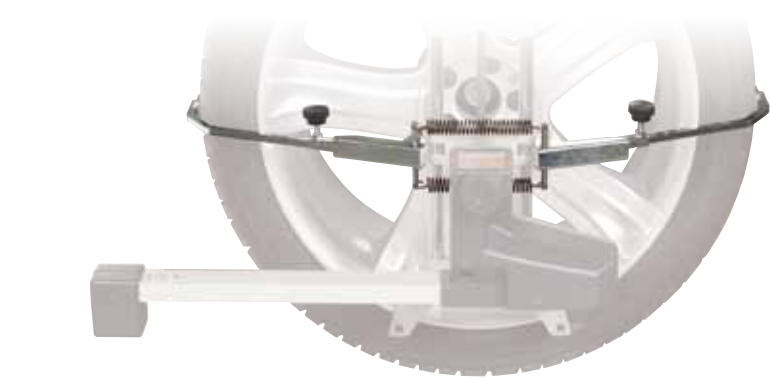

Clamp supporting arms and set of tips for tyres with external diameter up to 40" for CARS and up to 50" for TRUCKS

*Grips for all rims and tyres are available*



Metal 48 mm grips with reference surface to optimize runout, rubbered to prevent scratches on alloy rims



Metal grips for clamping on steel rims from the inside



Metal 80 mm universal grips for 4-WD, SUV and light trucks



120 mm Universal metal grips for truck and bus wheels

## STANDARD CONFIGURATIONS



**DWA 1500L**



**DWA 1500W**



**DWA 1500W light**

### DESCRIPTIONS

Computer - 19" monitor - printer



Car & truck software and database



2 Car sensors + 2 truck sensors



4 Clamps + safety elastic band  
+ 3 set of grips



2 Car turnplates + 2 Truck turnplates



Steering lock + Brake pedal lock



## OPTIONS



Adaptor rod for semitrailers' king pin

## TECHNICAL DATA

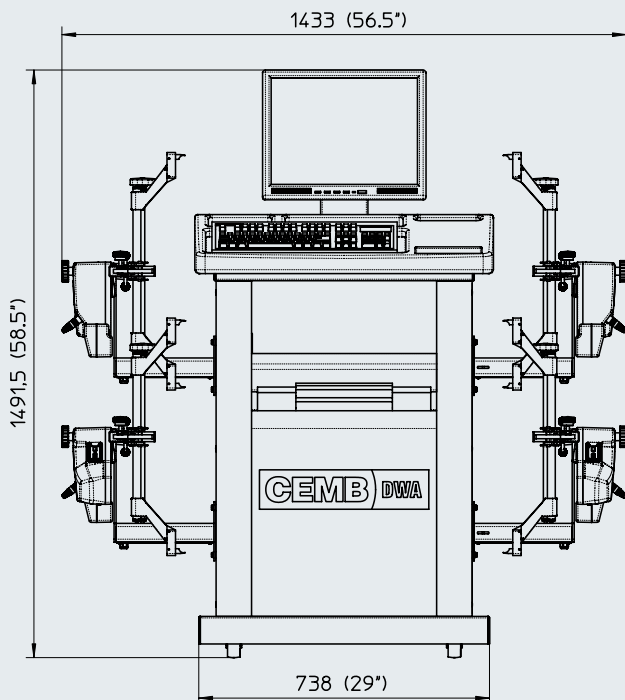

### Package dimensions and gross weight:

type 1: 47"x60"x51" (485 pound)

type 2: 41"x35"x59" + 53"x29"x45" (total 529 pound)

**Net weight:** 342 pound



# CEMB

BALANCING MACHINES



### CEMB S.p.A.

Via Risorgimento, 9  
23826 Mandello del Lario (LC) Italy  
www.cemb.com



### Garage equipment division

#### CEMB - ITALY

#### Plant and Training Center

phone +39 0341 706369

fax +39 0341 700725

garage@cemb.com

### CEMB USA

#### BL Systems Inc.

2873 Ramsey Road

Gainesville, GA 30501 - USA

Phone +001 678 717 1050

Fax +001 678 717 1056

sales@cemb-usa.com

All the data and features mentioned in this catalogue are purely for information and do not constitute any commitment on the part of our company, which reserves the right to make any and all alterations it may consider suitable without notice.